

Trophy Horsemanship Open

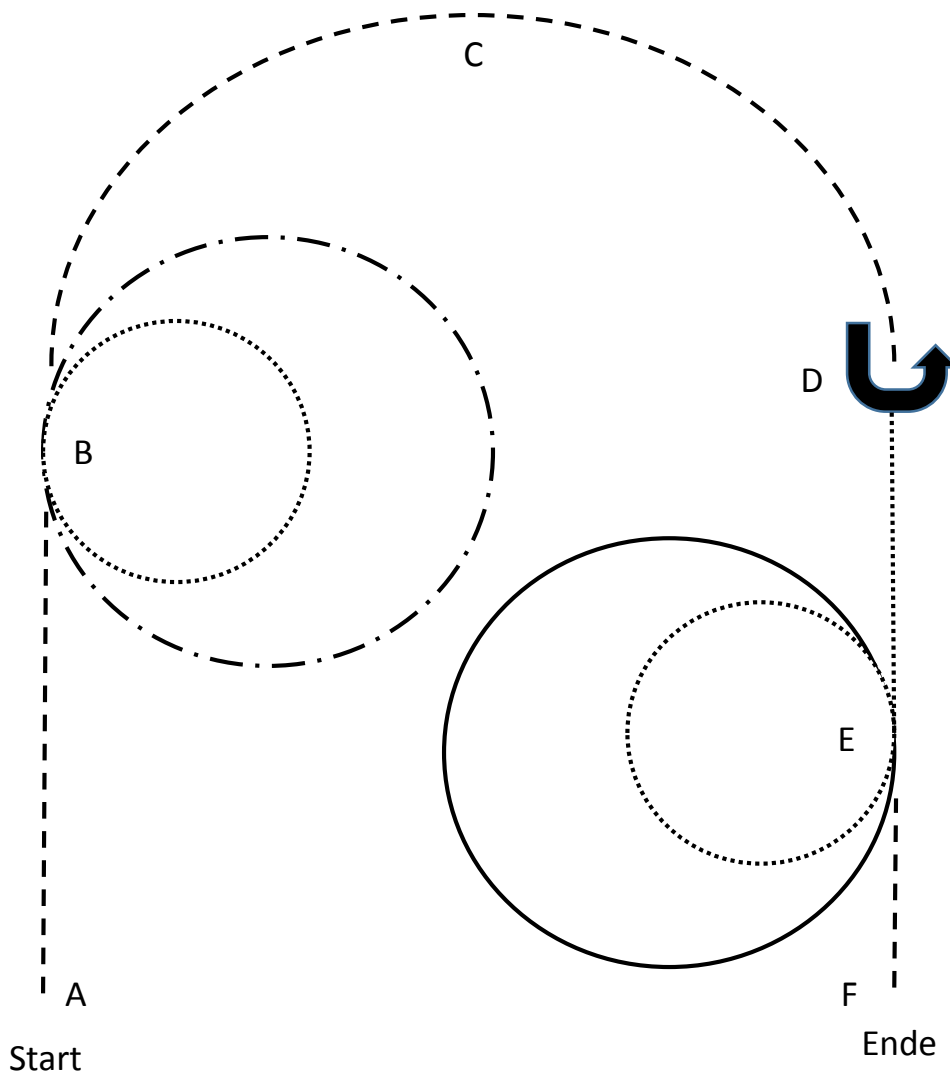

- | | |
|-----------|--|
| A | Be ready at the first cone |
| A – B | Jog from cone A to cone B |
| B | Extended Jog: Perform a big circle to the right |
| B | Walk a small circle to the right |
| B – C – D | Jog from cone B, round cone C to cone D |
| D | Stop and perform a 360° turn to the left |
| D – E | Walk from cone D to cone E |
| E | Walk a small circle to the right |
| E | Lope a big circle to the right on the right lead |
| E – F | Jog from cone E to cone F |
| F | Stopp |

Legend:

Jog: -----

Walk:

Lope: _____

Extended Jog: - - - - -

Turn: 

Marker: A, B, C, D, E, F

Any Horse Any Rider Horsemanship

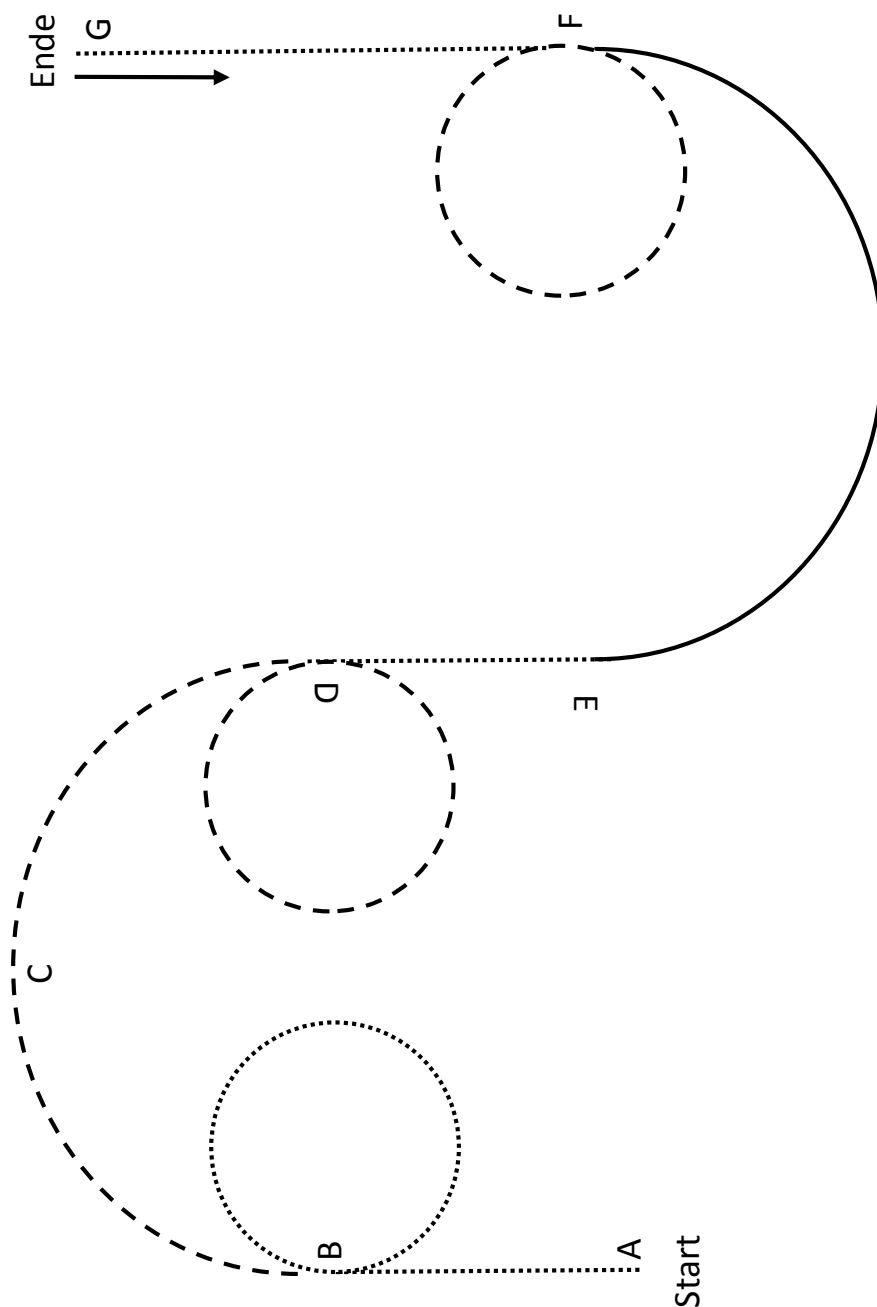

- A Be ready at the first cone
- A – B Walk from cone A to cone B and a small circle round B to the right
- B – C – D Jog from cone B, round cone C to cone D
- D Jog a small to the right
- D – E Walk from cone D to cone E
- E – F Lope half a big circle to cone F on the left lead
- F Jog a small circle to the left
- F – G Walk from cone E to cone F
- G Stopp and back up one horselength

Legend:

Jog: - - - - -

Walk:

Lope: _____

Back up: ← _____

Marker: A, B, C, D, E, F, G

Walk / Trott Horsemanship

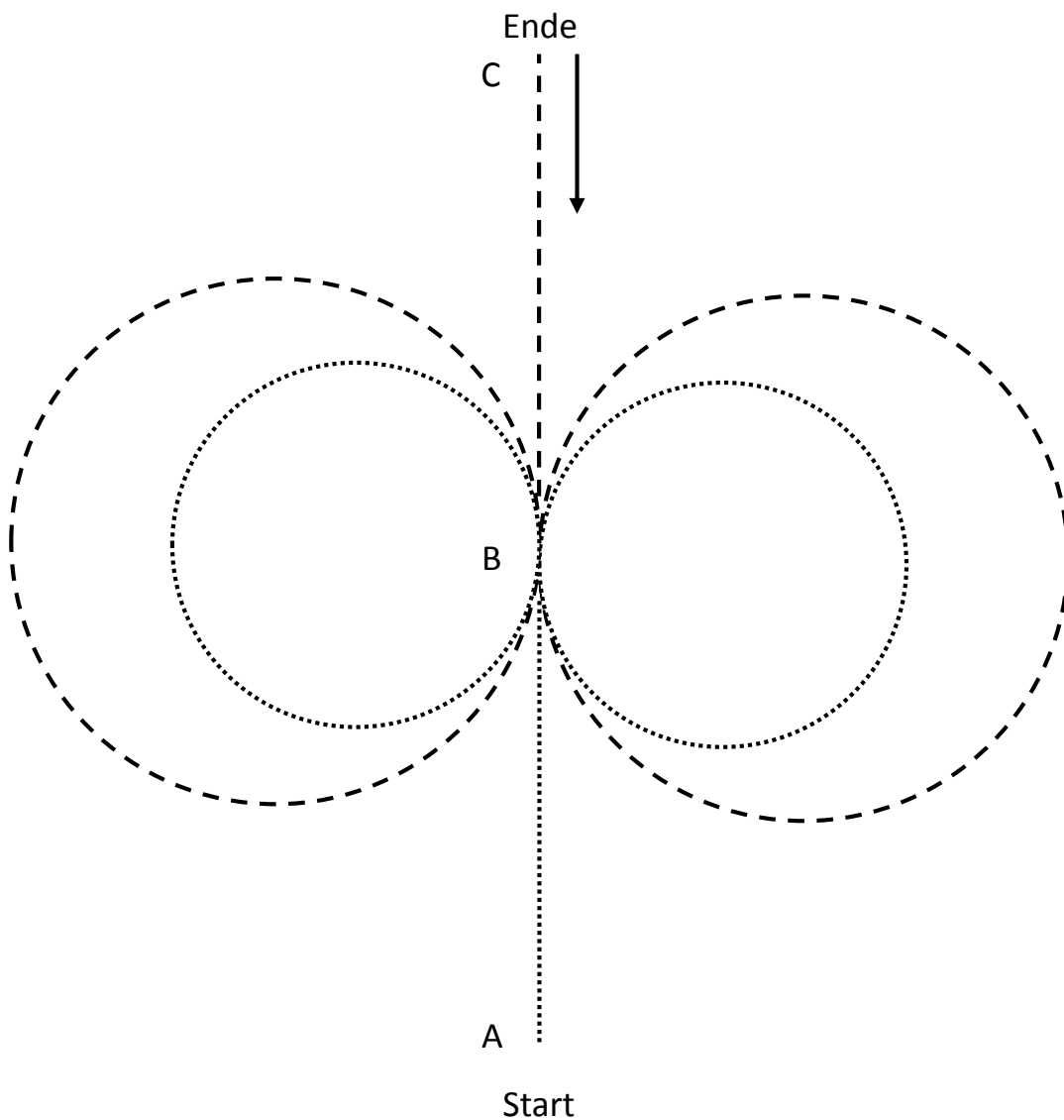

- | | |
|-------|----------------------------------|
| A | Be ready at the first cone |
| A – B | Walk from cone A to cone B |
| B | Trott a big circle to the right |
| B | Walk a small circle to the right |
| B | Walk a small circle to the left |
| B | Trott a big circle to the left |
| B – C | Trott from cone B to cone C |
| C | Stopp and back up 5 steps |

Legend:

Trott: - - - - -

Walk:

Back up: ←

Marker: A, B, C, D

VWB Einsteiger Horsemanship

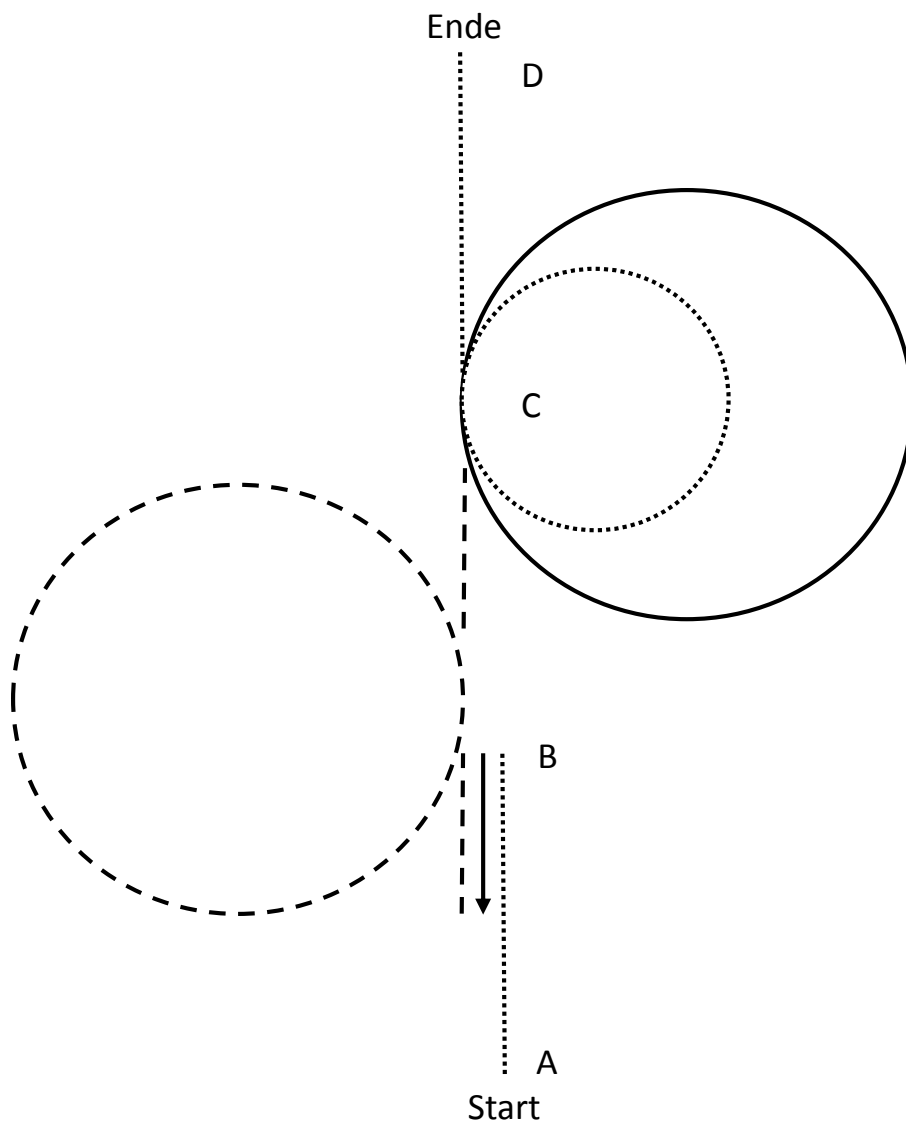

- A Be ready at the first cone
- A – B Walk from cone A to cone B
- B Back up one horselength
- B Jog a big circle to the left
- B – C Jog from cone B to cone C
- C Lope a big circle to the right on the right lead
- C Walk a small circle to the right
- C – D Walk from cone C to cone D
- D Stopp

Legend:

Jog: - - - - -

Walk:

Lope: _____

Back up: ← _____

Marker: A, B, C, D

VWB Jugend Horsemanship

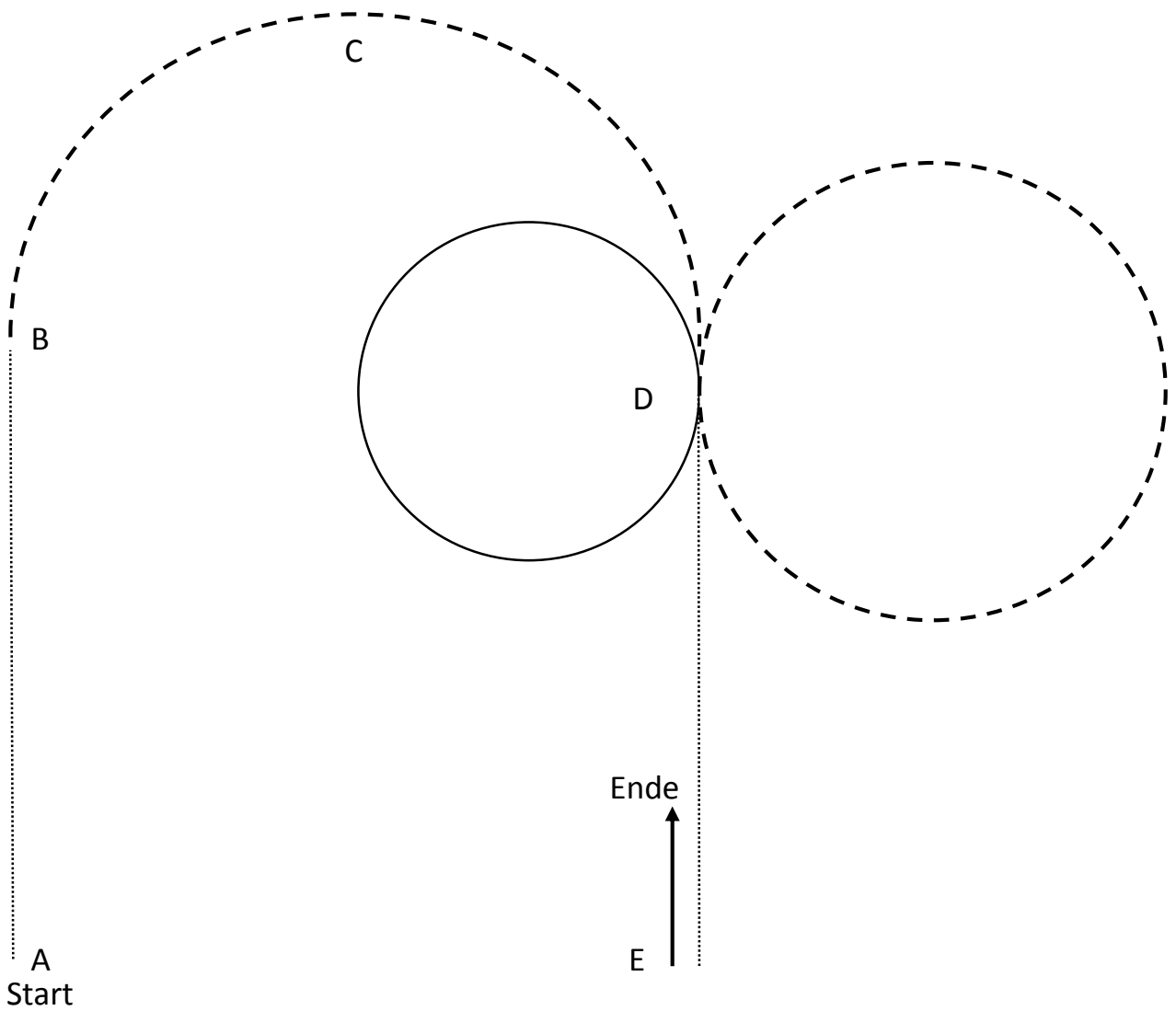

- A Be ready at the first cone
- A – B Walk from cone A to cone B
- B – C – D Jog from cone B, round cone C to cone D
- D Lope a small slow circle to the right on the right lead
- D Jog a big circle to the left
- D – E Walk from cone D to cone E
- E Stopp and back up one horselength

Legend:

Jog: - - - - -

Walk:

Lope: _____

Back up: ← _____

Marker: A, B, C, D, E

VWB Amateur Horsemanship

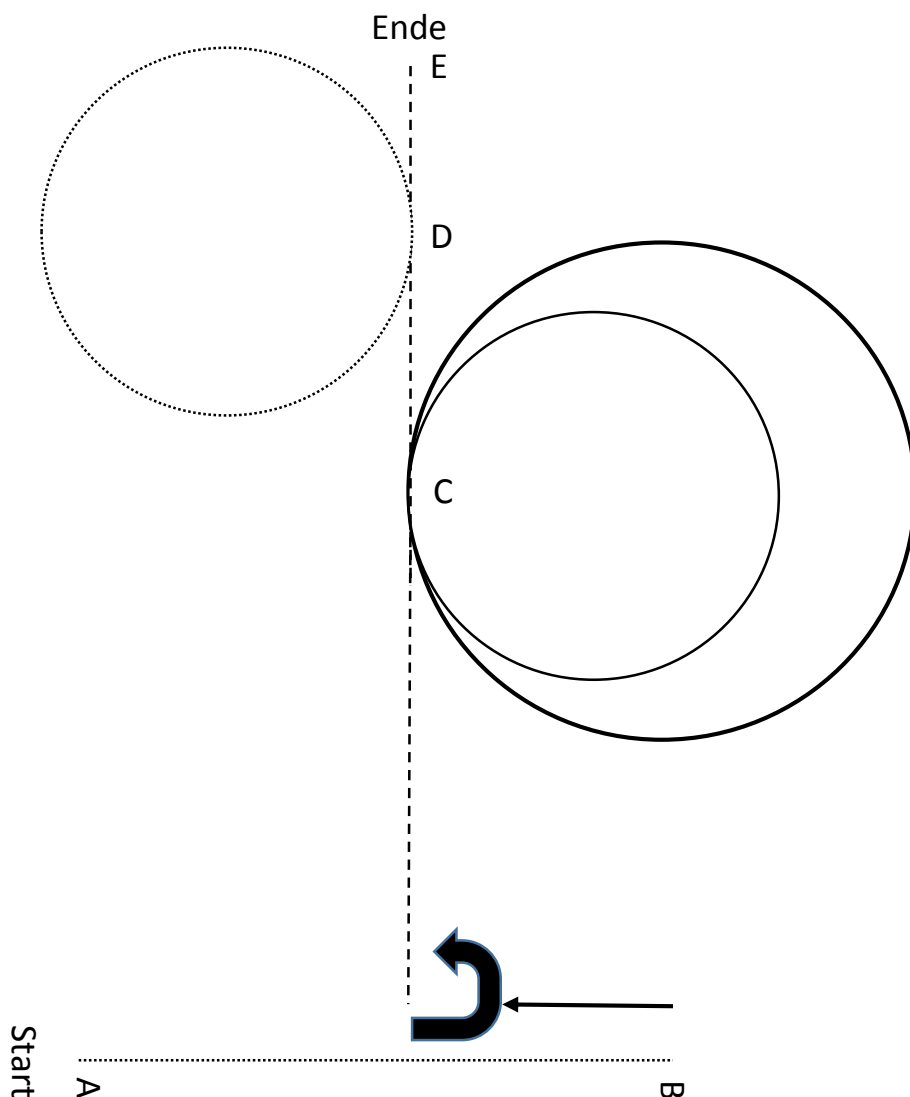

- A Be ready at the first cone
- A – B Walk from cone A to cone B
- B Back up one horselength and perform a 90° turn to the left
- to C Jog to cone C
- C Lope a fast and big circle to the right
- C Lope a small and slow circle to the right
- C – D Jog from cone C to cone D
- D Walk a small circle to the left
- D – E Jog from cone D to cone E
- E Stopp

Legend:

Jog: - - - - -

Lope: _____

Back up: ←

Walk:

Turn: 

Marker: A, B, C, D, E